

limelight

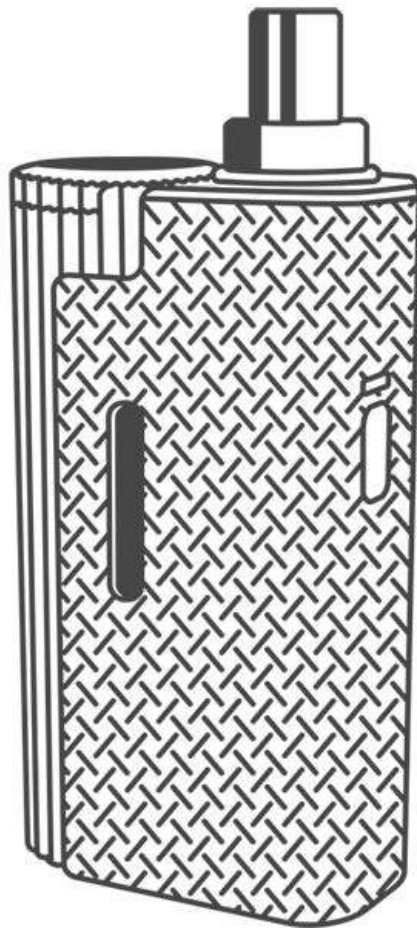

frollic

THERMAL EXTRACTOR

USER MANUAL

TABLE OF CONTENTS

Page 1	- Table of contents
Page 2	- Safety precautions
Page 3	- Technical specification
Page 4	- Frolic elements
Page 5	- Notifications
Page 6	- Operating the Frolic
Page 7	- Operating the Frolic
Page 8	- Operating the Frolic
Page 9	- Filling the Frolic with herb
Page 10	- Filling the Frolic with herb
Page 11	- How the Frolic works
Page 12	- How the Frolic works
Page 13	- Attachments/battery
Page 14	- Airflow control
Page 15	- Maintenance and cleaning
Page 16	- Maintenance and cleaning
Page 17	- Maintenance and cleaning
Page 18	- Contact and support

SAFETY PRECAUTIONS

Read these instructions carefully and completely before using the Frolic.

- Designed for adult use only.
- Never leave the Frolic running unattended.
- Store in a dry place, 10–40 °C.
- Protect from extreme or rapid temperature shifts.
- Fits a user-replaceable 21700 cell; choose batteries with >25A discharge rating.
- Check battery condition and wrap before use.
- Secure the battery cap firmly.
- For safety, the Frolic shuts down automatically when a USB-C cable is attached.
- If dropped, restart and confirm proper function. Gentle warmth is normal; overheating or no heat means service is required and the device shouldn't be operated

Before use



Important: The Frolic is shipped with a safety sticker on the battery's negative pole to ensure safe transport. Please remove this sticker before using the device.

TECHNICAL SPECIFICATION

Package contents

- Frolic Extractor (With battery) x1
- User manual x1
- USB-C cable x1
- Cleaning brush x1
- O-Ring set + tool x1
- Cooling unit screen (Coarse) x3
- Oven screen (Fine) x3

Technical specification

Dimensions - 105x63x24mm

4.1 x 2.5 x 1.0 Inch

Weight - 245g /0.55lbs (With battery)

Battery - Molicel P50B 5000mAh

Input - USB-C 5V=2A

Temperature range -

- Session - 40-220°C (104-428°F)

- On demand - 40-240°C (104-464°F)

O-rings -

1.LOCK WHEEL-9mm ID/12mm OD/1.5mm

2.MOUTHPIECE-14mm ID/17mm OD/1.5mm

3.OVEN CAP-20mm ID/24mm OD/2mm

4.COOLER-41mm ID/45mm OD/2mm

5.AIRFLOW-10mm ID/13mm OD/1.5mm

6.TOOL-1.5mm ID/3.5mm OD/1mm

FROLIC ELEMENTS

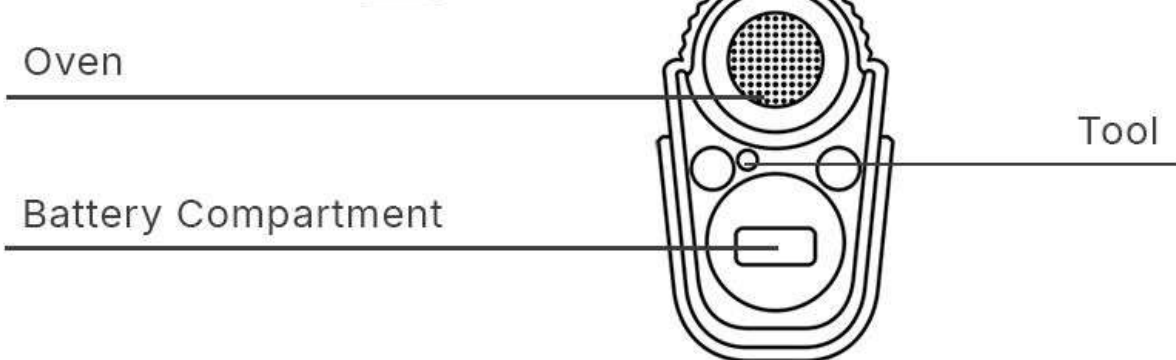
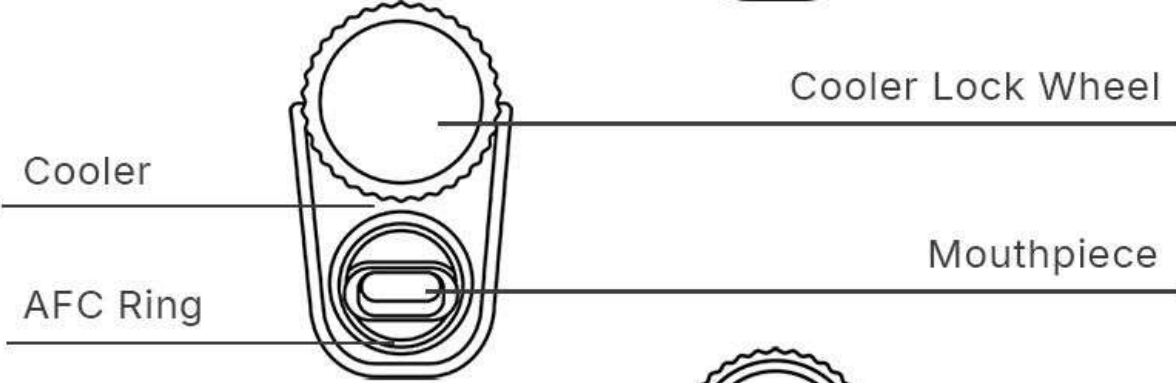
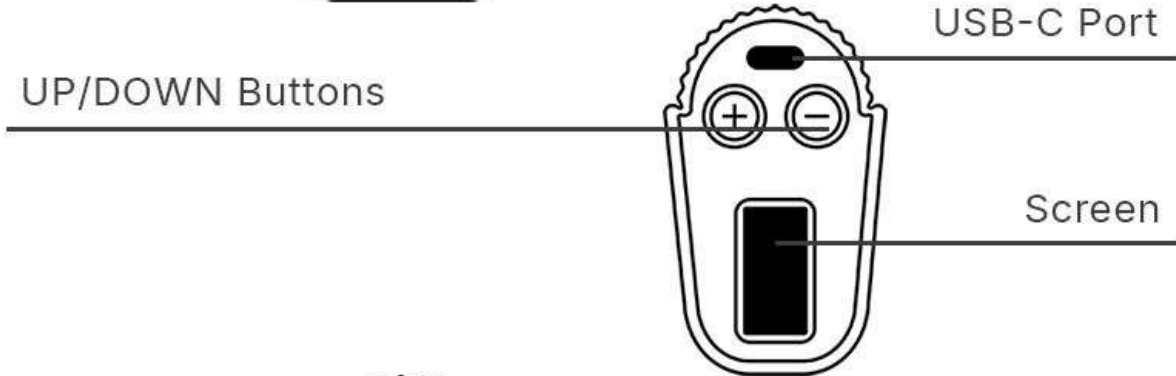
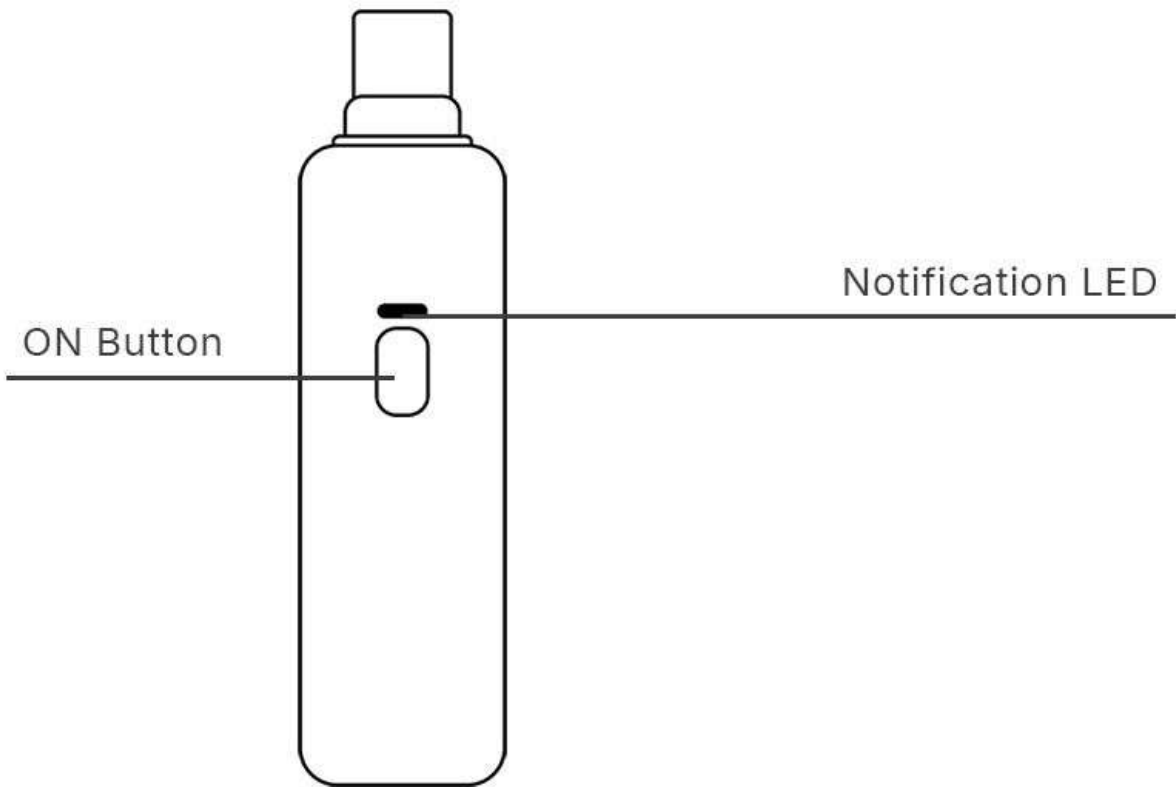

NOTIFICATIONS

The Frolic provides notifications through the display, vibration feedback, and a notification LED located above the ON button.

Refer to the table for details on each state and alert. Vibration and LED indicators can be enabled or disabled in the setup menu.

EVENT:	SCREEN:	VIBRATION:	LED:
Battery inserted	BATTERY INSERTED	VIBRATE X1	BLINK X1
Mod turns on	FROLIC ON	VIBRATE X3	BLINK X3
Heating up	TEMPERATURE ORANGE	/	ORANGE
Temperature reached	TEMPERATURE GREEN	VIBRATE X1	GREEN
Battery empty	BATTERY BAR BLINKS	VIBRATE LONG	/
Charging	BATTERY BAR CHARGING	/	/
Mod turns off	FROLIC OFF	VIBRATE X3	BLINK X3

OPERATING THE FROLIC

Setup menu

- With the Frolic turned off, press UP & DOWN keys together to enter the initial setup menu.

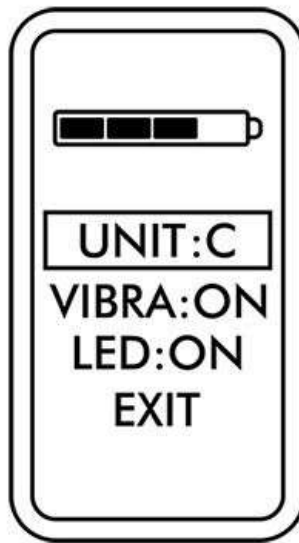

- Scroll through the options by pressing UP or DOWN buttons.
- Change the value by pressing the ON button.
- Exit the menu by moving to EXIT then pressing the ON button.

Turning the Frolic on/off:

- Press the ON button 3 times in succession.

OPERATING THE FROLIC

Main screen:

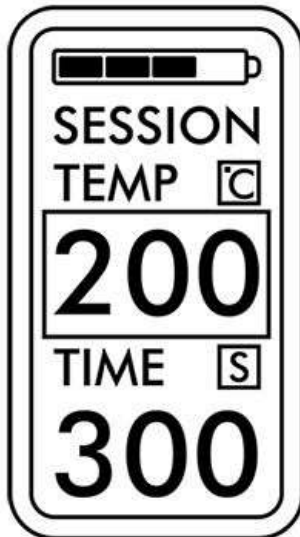

Battery bar

Mode bar

Temperature bar

Time bar

Battery bar - Shows the battery level and charging status.

Mode bar - Shows if the Frolic is in session or demand mode.

Temperature bar - Shows the set temperature (40-220°C in session mode and 40-240°C in demand mode).

Time bar - Displays the set duration of a session in session mode from 100-500s (Counts down to 0 when the heater is activated).

- Displays elapsed time in demand mode from 0-25s.

OPERATING THE FROLIC

- The active setting bar is displayed as outlined.
- When the heater is heating up, the temperature is displayed orange.
- When the temperature is reached, the temperature is displayed green.

1. Toggling through bars:

Press UP & DOWN buttons together.

2. Adjusting the values:

Press the UP or DOWN button to adjust the active setting. Holding the UP or DOWN button for more than 5 seconds increases the temperature or time change increment to 5°C.

3. Activating the heater:

Press the ON button when the Frolic is turned on.

- The Frolic remembers the set temperature and the set time settings from the previous use.

FILLING THE FROLIC WITH HERB

- Fill the Frolic with herb only when the oven is cold.

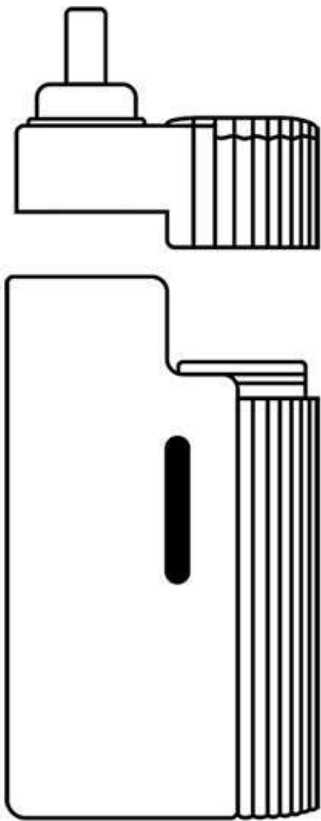

1. Remove the cooler

Pull the cooler up to access the oven (The cooler is held in place by the body and the oven O-ring)

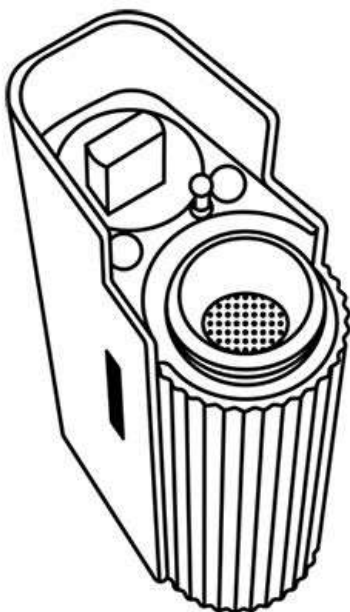

2. Fill the oven

Fill the oven with ground herb up to the brim of the black oven. Gently press the herb down using your finger or the supplied pin-tool. Use the supplied brush to remove any herb material around the oven.

FILLING THE FROLIC WITH HERB

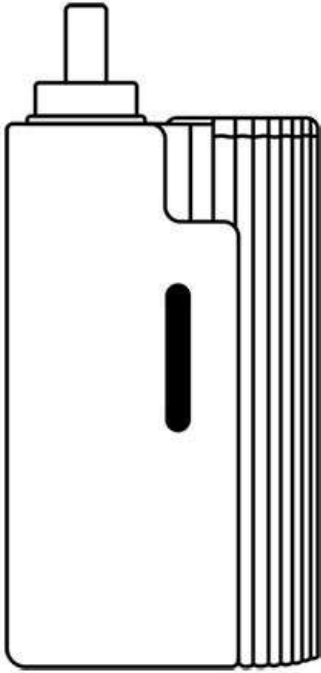

3. Put the cooler back

Put the cooler back onto the Frolic by pressing it down. Push it all the way down, the cooler should sit flush on the Frolic.

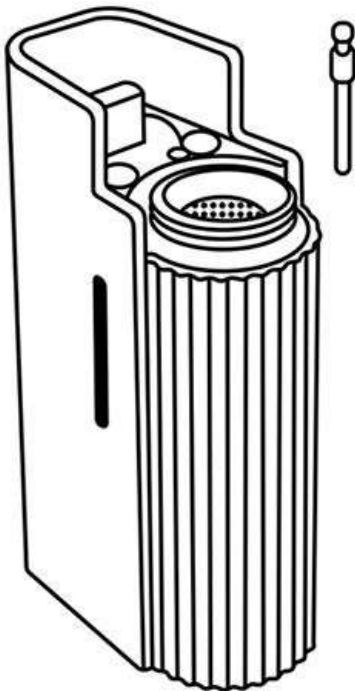

4. Refilling

Use the supplied pin-tool to remove the herb material from the oven before refilling the oven. Use the supplied brush to clean the oven screen and the cooling unit screen after each use.

HOW THE FROLIC WORKS

The Frolic is capable of working in either **SESSION** mode or **ON DEMAND** mode.

Session mode

- Press the ON button once to activate the heater.
- In session mode, the heater will remain on until the ON button is pressed again or the set session time is up.
- Take a long, steady draw through the mouthpiece.

Demand mode

- Press and hold the ON button until the temperature is reached.
- In demand mode, the heater is active only while the ON button is pressed.
- Take a draw through the mouthpiece while still holding the ON button.

HOW THE FROLIC WORKS

- When the heater is heating up, the LED and the temperature on the screen lights up orange
- Once the temperature is reached, the Frolic will vibrate, the LED and the temperature on the screen will turn green.
- The initial heat up time will be take around 5 seconds. Every next heat up time in demand mode will take less than 2 seconds.
- During the first draw vapor will feel weaker, and the second draw should be full. Due to the convection heating, hot air needs to pass through the herb in order to cook it properly.
- The performance of the Frolic depends on how the herb has been ground, compressed, the set temperature, longevity of your draw and airflow adjustment.



WARNING: Vapor at temperatures above 210°C might be too harsh for direct inhalation by some users. Use with caution or inhale through an additional cooler.

ATTACHMENTS/BATTERY

Attachments

- These allow the Frolic to be attached to a water cooler.
- The attachments come in two standard sizes: 14mm and 18mm and can be purchased separately.

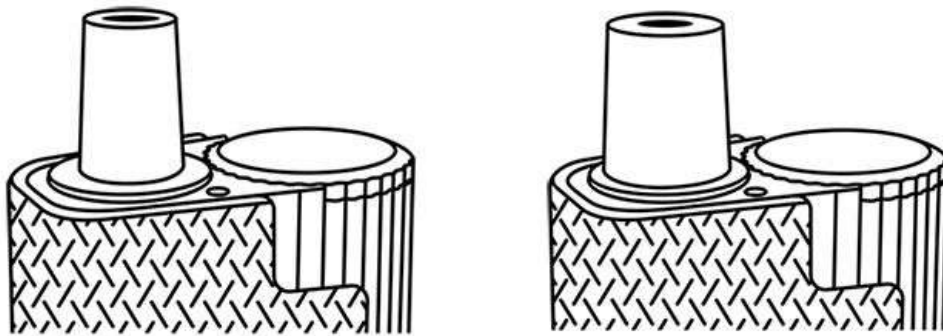

Removing the battery

- The Frolic has a removable battery. In order to remove the battery from the Frolic, simply unscrew the battery cap which is located at the top of the Frolic. When returning the battery, make sure that the positive is facing down and that the battery cap is screwed in tightly. TIP: The bottom of the mouthpiece doubles as a tool for the battery cap.

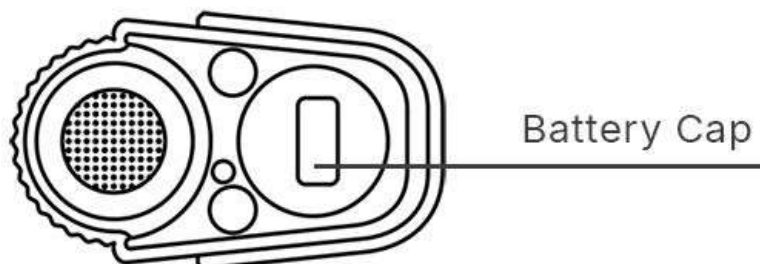

AIRFLOW CONTROL

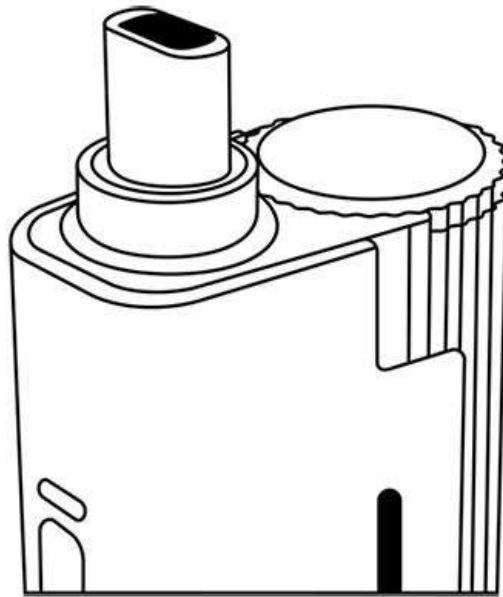

The Frolic is equipped with airflow control capable of regulating the airflow from 25l/min to 0l/min.

Adjusting the airflow

To reduce the airflow, rotate the AFC ring clockwise and to increase the airflow, counter-clockwise.

After adjusting the airflow, hold the AFC ring in place and align the tip.

TIP: Keep the airflow closed to keep the smell contained.

MAINTENANCE AND CLEANING

Cleaning the oven

- The oven of the Frolic needs to be cleaned once you notice the aluminum oven getting dirty. Pre heat the oven to 60°C, then wipe it clean with cotton dipped in alcohol.

Cleaning the cooling unit

- Separate the mouthpiece and the AFC ring from the cooling unit by pulling them away.

- Rotate the aluminum locking wheel counter-clockwise and lift it up.

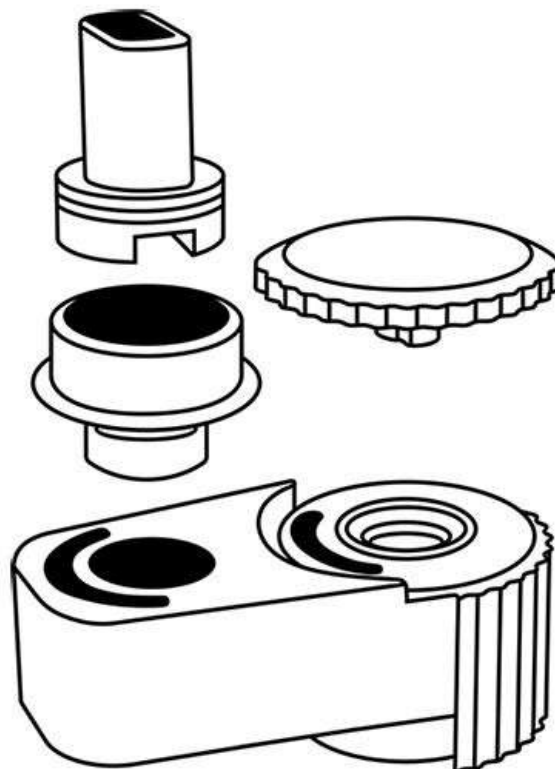

MAINTENANCE AND CLEANING

- Use the pin-tool to push on the inner part of the cooling unit out through the mouthpiece hole and the lock wheel to push on the inner part of the cooling unit through the lock wheel hole.

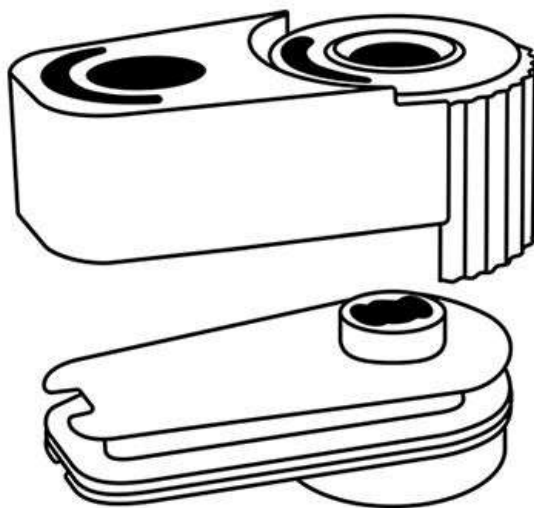

- With all the parts separated and O-rings removed, soak them either in warm water or alcohol, wipe, rinse with water, then let them dry. Alternatively, you can use an ultrasonic cleaner or wash the parts (EXCLUDING THE ALUMINUM LOCK WHEEL AND O-RINGS) in the dishwasher.

Occasionally, you can perform a more thorough cleaning process by removing the O-rings (O-ring removal tool included in the package) and by removing the mesh screen by pushing it out from the top using the pin-tool.

MAINTENANCE AND CLEANING

Replacing the oven screen

- The fine mesh screen is intended for the oven.
 - The coarse mesh screen is intended for the cooler.
-
- When the oven screen gets clogged from herb oils, it should be replaced.
 - Use the O-ring removal tool to gently lift the screen from the side and remove it from the oven.
 - Place the new screen into the oven with the curved side (concave) facing upwards, then press down on the screen so it sits flush with the oven bottom.

CONTACT & SUPPORT

If you need any additional assistance with using your Frolic vaporizer or if you have any suggestions, you can contact us at:

support@limelightherb.com

or visit the support page on our website at:

www.limelightherb/support

Manufacturer:

Butternut doo, Kneza Milosa 129, 35000 Jagodina,
Republic of Serbia

Importer:



WWW.LIMELIGHTHERB.COM

Enjoy!

Disposal and Recycling



- This symbol indicates that this product and battery must not be disposed of with household waste.
- It should be taken to an appropriate collection point for the recycling of electrical and electronic equipment.
- Dispose of this product in accordance with local regulations.
- Please return used batteries to appropriate collection points for recycling in accordance with local regulations.
- Improper disposal may have negative effects on the environment and human health.



Hereby, Butternut doo declares that this product (Frolic TE) complies with the essential requirements and other relevant provisions of Directive 2014/30/EU (EMC), Directive 2011/65/EU (RoHS), and Directive 2001/95/EC (GPSD). The full text of the EU Declaration of Conformity is available at the following internet address:
<https://limelightherb.com/downloads/>



[MagicVaporizers](#) – Europe's Best Shop for Vaporizers

- Lowest prices
- Fastest shipping
- Most trusted warranty

